



WHY CHOOSE PRIMUS

With over 100 years' experience competing in the diverse and demanding European market, Primus has been built on the solid foundations of purposeful innovation and a passion to help customers get ahead in laundry. Primus develops industry leading, eco-friendly laundry solutions characterized by incomparable efficiency and stylish design.



FX65
6,5kg/13lb



FX80
7,5kg/18lb



FX105
10,5kg/24lb



FX135
13,5kg/31lb

2 FX MACHINES SOLD EVERY HOUR IN THE WORLD

Since its launch, the FX line has become Primus' flagship for many reasons you'll (re)discover in this brochure. Optimized consumptions, high and extremely reliable performance, stylish design and many different capacities have made FX washer-extractors the preferred equipment for a variety of laundries, including: laundromats, restaurants, spas, hotels, gyms, healthcare facilities and more.



FX180
18kg/39lb



FX240
24kg/52lb



FX280
28kg/61lb

OPTIMIZED CONSUMPTION

Water and energy use are huge concerns for every stakeholder and client in the industry. With this in mind, the FX Line has been designed to achieve extremely low water and energy consumption. FX washer-extractors are standard equipped with revolutionary CASCADE™ DRUM.

25% LESS HUMIDITY

20% LESS ENERGY FOR DRYING*

PRIMUS introduces the unique CASCADE™ DRUM

The CASCADE DRUM™ concept results in more perforations in the drum over the same surface area – so water extraction is much more efficient without your linen sticking to the drum, thus simplifying unloading.

The CASCADE shape of the drum holes provides an extra mechanical action that produces an even better washing result.



- Simpler unloading, as your linen does not stick to the drum
- Maximum water extraction
- Less residual moisture, due to the inclination of the bulges
- Better washing performance as bulges provide an extra mechanical action

15% LESS WATER CONSUMPTION

ECO-FRIENDLY FOCUS

The FX machines are designed to consume minimum water without affecting the wash performance. Conveniently placed under the low water level, the heating elements and temperature sensor now enable more water saving with the same high wash quality.

EXPERTS CERTIFIED MOPS WASH SOLUTION

Primus offers a complete, tailor-made mop cleaning solutions for your facility, fitting the needs of any segment (Hygienic cleaning, Professional cleaning or Heavy duty cleaning). The FX range mop-washing programs are WFK certified and ensure disinfection at low temperature with optional dirt collector.

- Special programs to perfectly wash mops, wipers and more for soft mount machines
- Cycles developed for various mop head soil levels by experts in facility management
- Cycles are suitable for dry or wet mop, cotton or micro fiber.
- Tested and certified for disinfection at 40°C
- Stainless steel dirt collector optional system with capacity up to 280 L
- And, as always, PRIMUS exceptional long lasting and wash quality



TESTED AND CERTIFIED
BY EXPERTS FOR
DISINFECTION AT 40°C¹



Number of mops per load *	FX65 MOP	FX80 MOP	FX105 MOP	FX135 MOP	FX180 MOP	FX240 MOP	FX280 MOP
Mops 100g**	59	68	95	122	162	216	252
Mops 180g**	33	38	53	68	90	120	140
Mops 200g**	29	34	47	61	81	108	126
Mops 230g**	25	29	41	53	70	94	110
Microfiber cloths 16g	366	422	591	759	1013	1350	1575
Microfiber cloths 22g	266	307	430	552	736	982	1145
Microfiber cloths 25g	234	270	378	486	648	864	1008

EXCEPTIONAL DESIGN AND ERGONOMICS

Style is a strong part of Primus DNA . The FX Line has been designed with elegance and ergonomics in mind, so owners and operators can get the most out of sleek and extremely functional equipment.

- **INNOVATIVE AND USER-FRIENDLY CONTROL PANEL**

The control panel is inclined to make the operator's work more ergonomic. Options in the menu scroll up and down, making it easier for any customer to understand and use them. Our display provides clear guidance to users. For instance, it shows which soap hopper compartment to use.

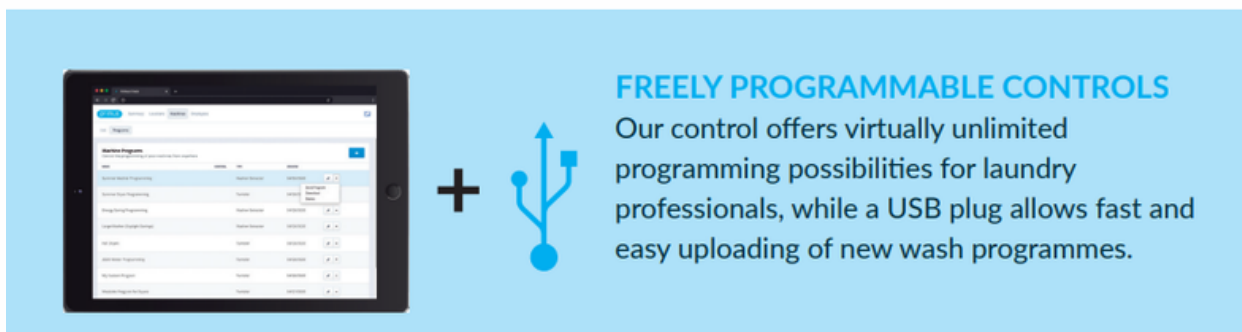

- **EXTRA LARGE DOORS FOR FASTER LOADING**

At Primus, we know that the diameter of the door means speed, when it comes to loading and unloading. With that in mind, we calculated the maximum diameter possible for each model, while also making sure the door opens 180 degrees.

- **REDESIGNED EASY TO REACH SOAP HOPPER**

The soapbox offers four compartments, suitable for powder or liquid soap. For additional ease-of-use, the compartments are now located at the front of the lid and next to each other. To make things easier for the owner, all compartments have been designed to allow easy access during service. The compartment for the main wash is modular, so the size of the cup can be switched depending on the size of the machine. The compartments can be covered (covers are optional) to prevent customers from making mistakes.

- **EASY INSTALLATION, EASY ACCESS TO MACHINE PARTS**

The FX Line is softmounted, to enable a fast installation with the best G-Force possible. All the vital parts of the machines - heating elements, drain, control panel - can be accessed from the front. A USB connection inside the control panel makes programming faster and easier.

NEW XCONTROL FLEX PLATFORM

GET AHEAD IN CUSTOMER EXPERIENCE AND CLOUD BASED PROGRAMMING CAPABILITIES

Primus' latest control, XControl FLEX platform, features an enhanced customer experience and brand-new functionalities for connectivity and data accessibility available anywhere, everywhere, in the cloud.

FEATURES & BENEFITS

- **7" full color touch screen display.**
Easy to read from any angle and customizable display
- **Intuitive user-friendly interface**
Offering all data at a glance. This best-in-class interface offers an excellent operator guidance
- **Clear step-by-step instructions available in 34 languages.**
Simplifies operation for users, any selection is no more than two touches away
- **15 wash cycles for OPL (12 for VEND) & 8 easy-to-understand cycle modifiers**
- **Wash cycles can be customized for specific needs**
- **Machine programming & performance data accessible through cloud.**
Allows owners to remotely access live machine data on mobile device





Primus i-Trace® integrates all aspects of business management through one partner—Primus. Mobile payment solutions. Financial and operational data and analytics. Customer engagement. Service and maintenance. It's all there in one, simple, cloud-based platform.

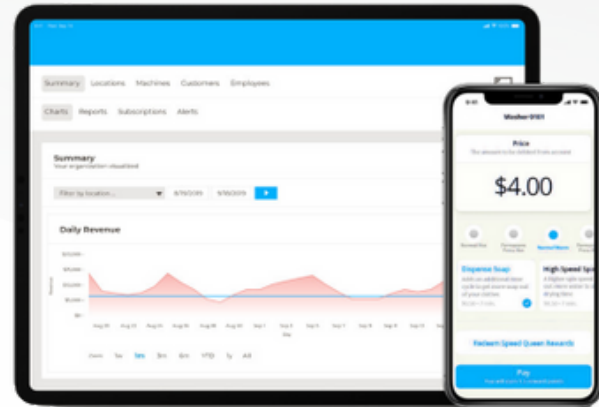

LAUNDRY MANAGERS & LAUNDROMAT OWNERS GET:



Fast, easy installation

Factory-supported, with little or no downtime and no software to maintain.



Future-proof technology

Upgrade and add new features quickly and seamlessly.



Integrated management platform

Single-source data and analytics for customers, machines and locations.



Simple interface

Easily track and optimize financial and operational performance.



Peace of mind

Support from the world leader in vended laundry solutions.



Error alert tracking and notifications

Keep tabs on your machines from anywhere with customizable error tracking and notification settings.



Mobility

Control your laundromats from anywhere.



Multiple payment options

Less coin collecting saves time so investors can focus on running their business.



Centralized refunds

Issue refunds directly to online wallet for improved service and efficiency.



Primus app

Mobile payment creates best-in-class retail experience.



Compliance

Simple and secure payment processing with PCI DSS compliance.

PRIMUS I-TRACE®
IS AVAILABLE ON:



DESKTOP



TABLET



MOBILE



ALL THE BENEFITS OF OUR ECO3 WASH SUSTAINABLE TECHNOLOGY ...

At Primus, we care about the environment, and we know that consumption costs are a key to your business. We developed our ECO3 technology with this focus, and made it available in standard on all FX models.

UP TO
-15%*



WATER CONSUMPTION

Optimising A passive space between tub and drum has minimised water consumption considerably.

UP TO
-20%*



ENERGY CONSUMPTION

Using lower water levels has reduced the energy required for heating as well.

UP TO
-25%*



RESIDUAL MOISTURE

Thanks to the final extraction's very high RPM, the laundry has exceptionally low residual moisture, which also reduces the energy required for drying.

WITH UNMATCHED PROFESSIONAL WASHING QUALITY

- As in all Primus equipment, only premium materials are used in the fabrication of our machines, to ensure one of the largest lifespans on the market.
- A soap mixer ensures the soap is properly blended with water before being in contact with the linen, optimizing the action of the soap and protecting loads from undiluted chemicals.
- Up to 13 liquid soap pumps can be added, to use exactly the right detergent dosages for each load.
- Our CASCADE DRUM™ provides additional mechanical action to deeply wash linens. In addition, the load is distributed more evenly in the drum, so water flows through the cylinder better, delivering an improved wash.
- A 400 G-Force spin helps bring loads to 50% residual moisture or less.
- Smartload semi-automatic weighing system makes sure you use only the water and energy needed.

OPTIONS

- XControl+
- XControl FLEX®
- Coin-operated timer (CPS)
- Stainless steel front and side panels
- USB plug (on the back panel)
- Easy Soap - liquid soap connection
- Liquid soap pumps
- Water recovery kit
- Steam heating version
- 3rd water inlet
- High capacity water inlets (FX180, 240)

PROGRAMS

PROGRAM	SPIN SPEED	WATER CONSUMPTION	ENERGY CONSUMPTION	REAL TIME	RINSES
1 HOT WASH 90° INTENSIVE	1120	131,4 l	4,3 kWh	57'52"	3
2 WARM WASH 60° INTENSIVE	1120	99,6 l	1,97 kWh	51'21"	3
3 COLOR WASH 40° INTENSIVE	1120	124,1 l	1,66 kWh	58'44"	3
4 BRIGHT 30° INTENSIVE	1120	86,0 l	0,52 kWh	34'27"	3
5 WOOLENS 15°	400	61,6 l	0,04 kWh	22'32"	3
6 HOT WASH 90°	1120	89,5 l	3,49 kWh	1:32'41"	3
7 WARM WASH 60°	1120	79,8 l	1,68 kWh	1:04'20"	3
8 COLOR 40°	1120	82,0 l	1,09 kWh	1:02'24"	3
9 BRIGHT 30°	1120	77,9 l	0,48 kWh	0:53'07"	3
10 ECO HOT 90°	1165	69,4 l	2,86 kWh	1:00'58"	2
11 ECO WARM 60°	1165	58,5 l	1,44 kWh	43'02"	2
12 ECO COLOR 40°	1165	68,2 l	1,02 kWh	42'32"	2
13 ECO BRIGHT 30°	1165	60,3 l	0,54 kWh	32'06"	2
14 LOW SPIN	400	35,1 l	0,03 kWh	11'19"	1
15 HIGH SPIN	1165	38,7 l	0,13 kWh	19'05"	1

FX65 | FX80 | FX105 | FX 135

IDEAL FOR:

These FX models and their fast cycle times are designed to meet the requirements of on-premises laundries that need to keep loads moving and lack space for larger models. They are also available with professional mop programs WFK certified that ensure disinfection at low temperature with optional dirt collector.



FX105

10,5KG / 25LB

WASHER-EXTRACTOR	FX65	FX80	FX105	FX135
Maximum capacity 1:9	7 kg	9 kg	12 kg	15 kg
Capacity 1:10	6,5 kg	8 kg	11 kg	14 kg
Drum volume	65 l	75 l	105 l	135 l
Extraction speed	1165 RPM	1165 RPM	1075 RPM	1075 RPM
G-Force	400	400	400	400
Residual Moisture	45 %	45 %	45 %	45 %

TYPE		FX65	FX80	FX105	FX135
INNERDRUM					
Maximum capacity 1:9	kg (lb)	7 (15)	9 (20)	12 (26)	15 (33)
Capacity 1:10	kg (lb)	6,5 (13)	7,5 (18)	10,5 (24)	13,5 (31)
Volume	litres	65	75	105	135
Diameter	mm	530	530	620	620
DRUM SPEED					
Wash	rpm	49	49	49	49
Extraction	rpm	1165	1165	1075	1075
G-FACTOR					
		400	400	400	400
HEATING					
Electricity (standard)	kW	6 / 9	6 / 9	6 / 9 / 12	9 / 12
Steam	bar	1 - 8	1 - 8	1 - 8	1 - 8
Hot water	°C	90	90	90	90
Sound pressure level	dB (A)	< 65	< 65	< 65	< 65
Water valves connection	BSP	3/4"	3/4"	3/4"	3/4"
Water pressure	kPa	100-800	100-800	100-800	100-800
Rec. water pressure	kPa	300-500	300-500	300-500	300-500
Water inlet	l/min	20	20	20	20
Drain valve	outer Ø mm	76	76	76	76
Flow amount with drain valve	l/min	210	210	210	210
Steam valve connection	BSP	1/2"	1/2"	1/2"	1/2"
Steam pressure	kPa	100-800	100-800	100-800	100-800
DIMENSIONS					
Size H×W×D	mm	1135×710×740	1135×710×790	1245×795×795	1245×795×945
Net weight	kg	170	185	210	255
TRANSPORT DATA					
Packed H×W×D	mm	1245×750×840	1245×750×840	1345×835×840	1345×835×985
Gross weight	kg	180	200	235	275

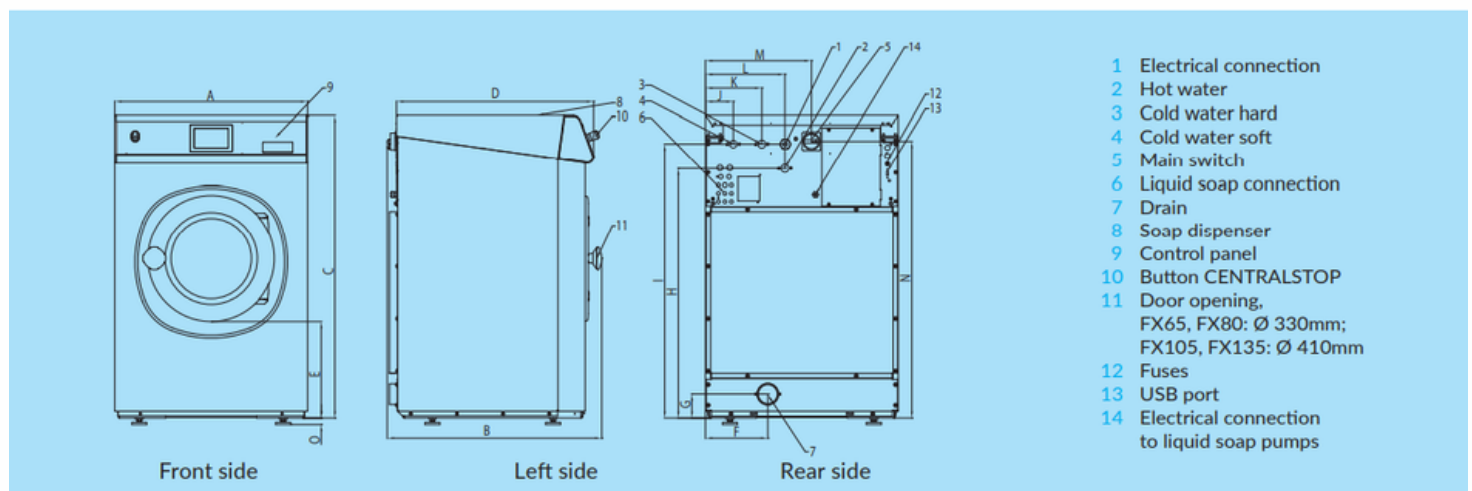

	A	B	C	D	E	F	G	H	I	J	K	L	M	N	O
FX65	710	740	1135	676	349	230	82	914	1004	113	218	293	390	1020	24
FX80	710	790	1135	726	349	230	88	920	1010	113	218	293	390	1020	24
FX105	795	795	1245	761	342	230	88	1030	1120	103	208	293	475	1130	24
FX135	795	945	1245	911	342	230	88	1030	1120	103	208	293	475	1130	24
	width	depth	height												



		FX80
Water consumption	l/kg	6,6
Electricity consumption	kWh/kg	0,18

* Program No 11

FX180 | FX240 | FX280

IDEAL FOR:

These FX models are built to serve a variety of on-premises laundries that are processing large volumes of laundry daily. They are also available with professional mop programs WFK certified that ensure disinfection at low temperature with optional dirt collector.



FX280

28KG / 70LB

WASHER-EXTRACTOR	FX 180	FX 240	FX 280
Maximum capacity 1:9	20 kg	27 kg	32 kg
Capacity 1:10	18 kg	24 kg	28 kg
Drum volume	180 l	240 l	280 l
Extraction speed	980 RPM	980 RPM	915 RPM
G-Force	400	400	350
Residual Moisture	45 %	45 %	45 %

