



## FX350 | FX450 | FX600 SOFTMOUNT WASHER-EXTRACTORS



**TOUCH CONTROL AVAILABLE**  
Multilingual user-friendly 7" touch control



**CLOUD-BASED PLATFORM**  
to easily monitor your laundry everywhere and at any time



**IMPROVED DURABILITY**  
for your peace of mind with a 3-year warranty



**AUTOMATIC WEIGHING SYSTEMS**  
Automatically adapts amount of water and detergent based on the wash load



**CASCADE DRUM TECHNOLOGY**  
Extra mechanical action thanks to its cascading shape of the surface

### FEATURES & BENEFITS

#### Features

- Stainless steel drum and tub
- Patented soap hopper
- Easy Soap™ - liquid soaps connection
- Easy access to all vital parts from the front
- Large door opening for easy loading & unloading
- 2x large drain valves (Ø 76 mm)
- Ergonomic height of door and control position for an easy operation
- Bumper (front side protection)

#### Options

- Liquid soap connection and pumps
- Water recovery kit
- Steam heating version
- 3<sup>rd</sup> water inlet
- Recycle drain valve and double door glass Execution
- Insulation for energy and heat & noise reduction
- Extra signalization (orange light + sound)
- Air operated water inlets
- Automatic weighing system through 4 weighing cells
- Tilting system: assists operators during loading & unloading

#### Control

- XControl FLEX PLUS - fully programmable and customizable cycles 7" touch screen.
- User-friendly screen with operating instructions built in as part of the control
- Complete control content available in 34 languages
- XControl - fully programmable control with 20 Pre-set programs and memory up to 99.

## SPECIFICATIONS

TYPE		FX350	FX450	FX600
<b>INNERDRUM</b>				
Capacity 1:09	kg (lb)	39 (86)	50 (110)	67 (148)
Capacity 1:10	kg (lb)	35 (77)	45 (99)	60 (132)
Volume	litres	351	452	601
Diameter	mm	914	914	1035
<b>DRUM SPEED</b>				
Wash	rpm	38	38	36
Extraction	rpm	839	839	788
G-FACTOR		360	360	360
<b>HEATING</b>				
Electricity	kW	24	36	54
Steam	bar	3-8	3-8	3-8
Sound pressure level	dB (A)	<75	<75	<75
Water valves connection	BSP	1"	1"	1"
Water pressure	kPa	100-800	100-800	100-800
Rec. water pressure	kPa	300-500	300-500	300-500
Water inlet	l/min	518	518	518
Drain valve	outer Ø mm	2x76	2x76	2x76
Flow amount with drain valve	l/min	2x 210	2x 210	2x 210
Steam valve connection	BSP	3/4"	3/4"	3/4"
Steam pressure	kPa	300-800	300-800	300-800
<b>DIMENSIONS</b>				
Size H*W*D	mm	1925x1315x1270	1925x1315x1502	1925x1315x1502
Net weight	kg	1010	1350	1500
<b>TRANSPORT DATA</b>				
Packed H*W*D	mm	2125x1425x1470	2125x1425x1700	2125x1425x1700
Gross weight	kg	1170	1490	1640

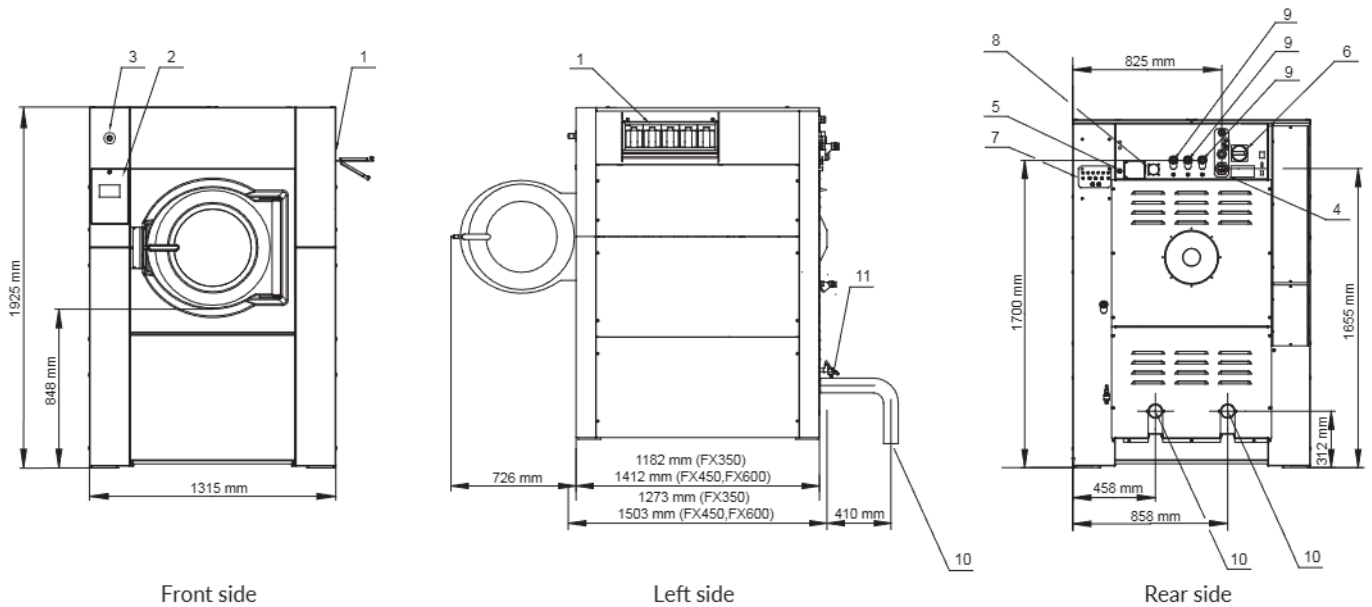

- |                          |   |                      |
|--------------------------|---|----------------------|
| 1. Soap hopper           | 5. Electrical connection to liquid soap | 9. Water connection  |
| 2. Keyboard              | 6. Main switch                          | 10. Drain valve      |
| 3. Emergency stop        | 7. Liquid soap pump connections         | 11. Water Sample Tap |
| 4. Electrical connection | 8. Air vent tub                         |                      |